

UNIQUE. INNOVATIVE.
Condensing technology
for combined boilers

SP Dual compact



Heating with firewood and pellets

For more than 50 years, Froling has specialised in efficiently using wood as a source of energy. Today the name Froling represents modern biomass heating technology. Froling firewood, wood chip and pellet boilers are successfully in operation all over Europe. All of our products are manufactured in our factories in Austria and Germany, and our extensive service network ensures that we can handle all inquiries quickly.



The fuels: firewood (up to 56 cm) and pellets



Wood is a home-grown and environmentally friendly fuel, that is highly sustainable. It is CO₂ neutral and is not affected by international crises. The production of firewood and pellets ensures stable jobs in the industry. Looking at it from an environmental and economical point of view, wood is the ideal fuel. The quality class is determined by the wood used.

Wood pellets are made of natural wood. The large volumes of wood shavings and sawdust generated by the wood-processing industry are compacted and pelleted without being treated beforehand. Pellets have a high energy output and are easy to deliver and store. These are just some of the advantages that make pellets the perfect fuel for fully automatic heating systems. Pellets are delivered by tanker and unloaded directly into your store.



SP Dual compact

Two systems perfectly combined - The new dual fuel boiler SP Dual compact

The SP Dual compact firewood and pellet boiler combines two perfect systems - it meets all the requirements for firewood and pellet fuels in two separate combustion chambers. Highly efficient and convenient - the SP Dual compact ensures low emissions and energy costs.

In addition, the SP Dual compact has just one heat exchanger, a return temperature control, a controller and a flue gas pipe, which can be used for both operating modes.



Pellet unit can be retrofitted at any time

The S1 Turbo F with pellet flange is the ideal solution for people who are currently only burning firewood. With the S1 Turbo F with pellet flange, the pellet unit can be retrofitted later at any time.

The SP Dual compact has important advantages even before it is put into the boiler room. It is so compact that installing it is child's play even in confined boiler rooms. The pellet burner of the SP Dual compact is supplied completely insulated and wired so all you need to do is plug it in. Thanks to its design with just a single exhaust pipe, it is particularly easy to retrofit a pellet unit at any time.

Wood gasifier technology firewood operation



- 1 Speed-regulated, low-noise induced draught fan for maximum ease of use.
- 2 WOS system (Efficiency Optimisation System) as standard, for high efficiency and user-friendly cleaning from outside. Optional with automatic WOS-Technik.
- 3 Large fuel loading chamber for logs up to 56 cm in length guarantees longer periods between refilling.
- 4 Top quality insulation to minimise radiant heat loss.
- 5 Carbonisation gas extraction system prevents smoke escaping during reloading.
- 6 Cladding to protect the inner wall of the boiler and for a longer service life.
- 7 Air-cooled fuel loading chamber and cleaning door to minimise radiant heat loss.
- 8 Special automatic pre-heating with regulated air ducts.
- 9 Servomotor for automatic control of heating, primary and secondary air.
- 10 High-temperature firebrick-lined combustion chamber (easy to replace parts).
- 11 Large cleaning port door for easy ash removal and cleaning from the front.

SP Dual compact pellet mode

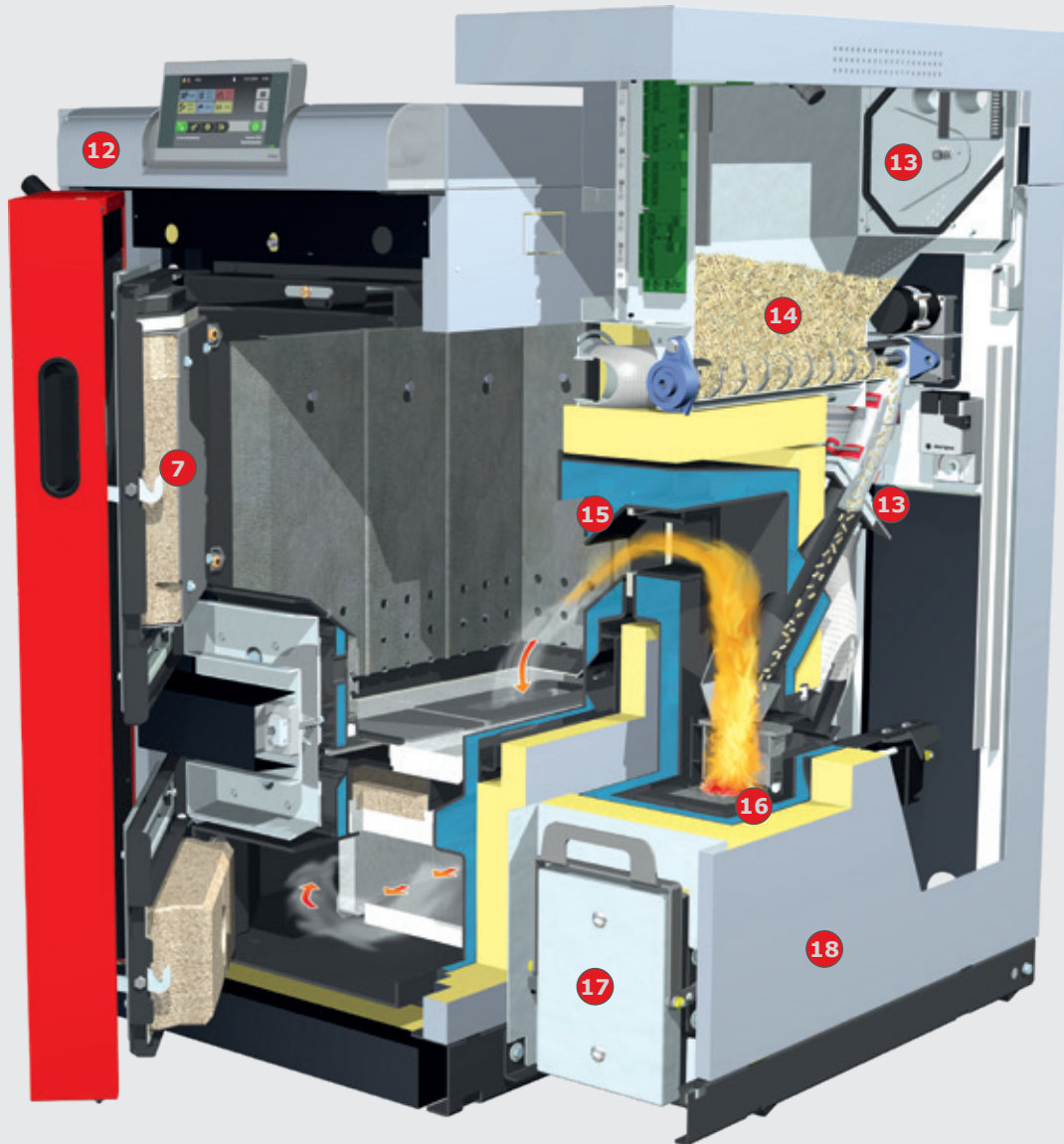

- 12 Lambdatronic S 3200 control with 7" touch display and innovative bus technology
- 13 Double slide valve system for maximum burn back protection.
- 14 Spacious pellet container with stoker screw and external suction module.
- 15 Water-cooled pellet flange with downward pointing design for safe operation.
- 16 High-quality water-cooled pellet burner with sliding grate for automatic ash removal and cleaning.
- 17 Practical, convenient ashcan for simple, dust-free emptying and long cleaning intervals.
- 18 Top quality insulation to minimise radiant heat loss.

The optimum unit

1 Feature: Large fuel loading chamber for half-metre pieces (up to 56 cm) with hot cladding

- Advantages:
- Easy loading
 - Long combustion time
 - Long lifespan

With 15 or 20 kW outputs, the SP Dual compact allows burning of firewood up to a length of 56 cm. Despite its compact design, the SP Dual compact has long reloading intervals and is already suitable for storage tank sizes from 825 litres. The aprons (hot cladding) protect the interior walls of the boiler, guaranteeing a long service life.

2 Feature: Water-cooled downward pointing pellet flange

- Advantages:
- Safe operation
 - Pellet unit can be retrofitted at any time

The downward pointing design of the pellet flange means that no impurities from the filling room can reach the combustion grate of the pellet unit.

3 Feature: High-temperature firebrick-lined combustion chamber

- Advantages:
- Low emissions
 - Easy cleaning
 - Long lifespan

The hot combustion zone in the combustion chamber keeps emissions levels low. The new shape of the combustion chamber makes it especially easy to clean. Furthermore, its new construction makes maintaining the combustion chamber a breeze as the firebricks are very easy to replace.



SP Dual compact

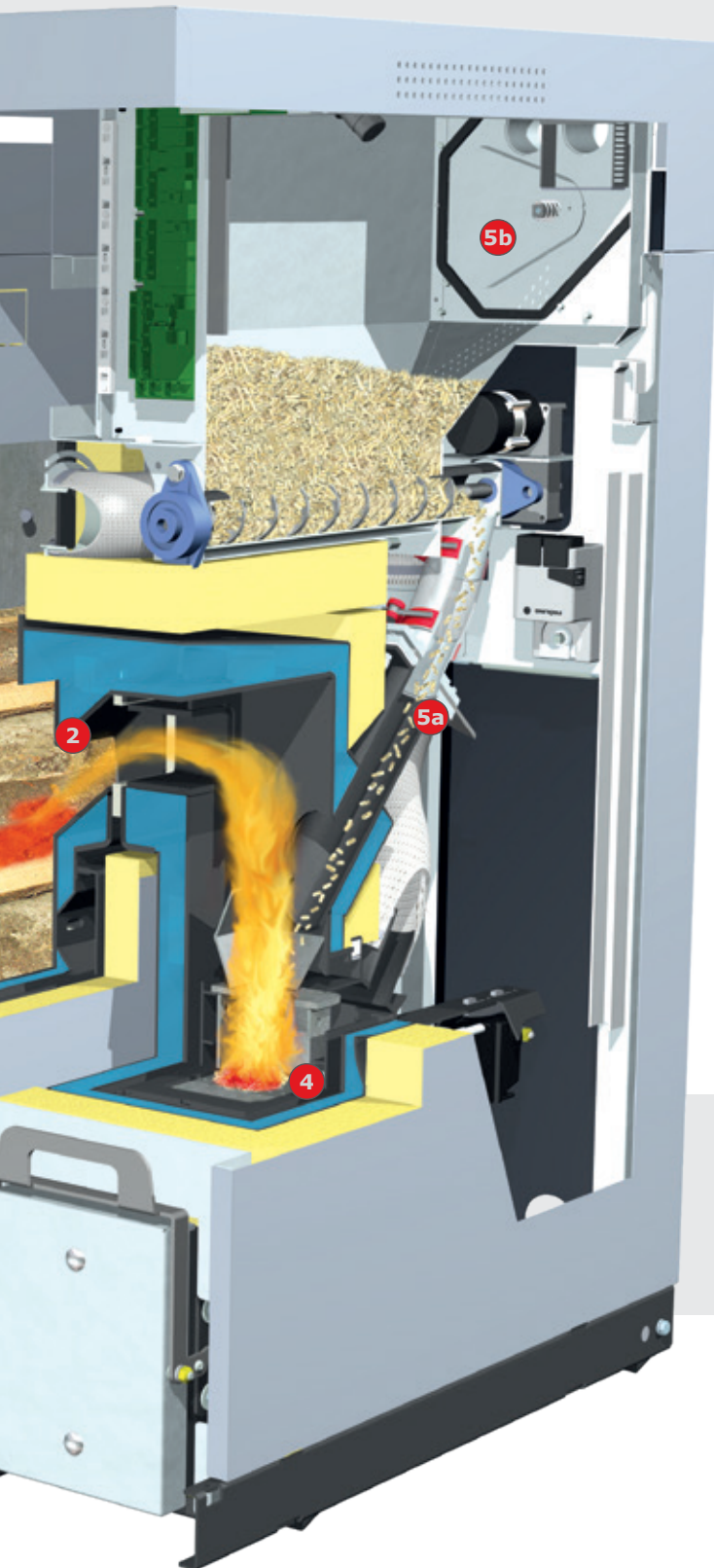

4 Feature: Automatic ignition and continued operation

- Advantages:
- No refitting required
 - Automatic change between firewood and pellets

The firewood can be ignited automatically using the pellet burner.

The two separate combustion chambers make it possible to change flexibly between firewood and pellets. If the firewood has burnt up and is not replenished within the time you specify (0-24 h), heating is continued automatically if heat is required.

If you open the loading chamber doors and insert more firewood, the pellet operation is interrupted and the SP Dual compact switches automatically back to firewood operation. The firewood can be ignited by the residual embers, manually or fully automatically using the pellet burner.

5 Feature: Comprehensive safety concept

- Advantages:
- The highest possible operating safety
 - Maximum reliability

The downpipe together with the tested burner gate valve (5a) and the store gate valve (5b) provide a double slide valve system, guaranteeing maximum burn back protection.

Impressive in the details

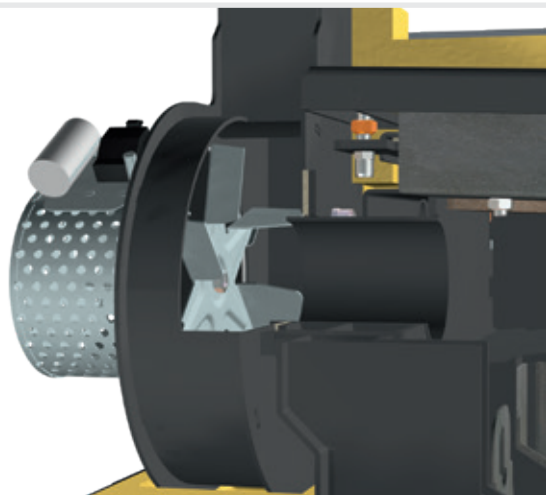

Feature: Speed-regulated induced draught fan

- Advantages:
- Maximum ease of use
 - Smooth boiler start
 - Constant stabilisation during combustion

The speed-controlled induced draught fan is a standard component of the unit, which further enhances the reliability of the SD Dual compact. This means that the boiler can be started easily even if the chimney is cold. The speed regulation device in the induced draught fan stabilises combustion throughout the heating process and adjusts the output according to requirements.

Feature: unique air duct system

- Advantages:
- Regulated supply of air for pre-heating
 - Optimal combustion conditions

A unique design: Both the primary and secondary air, as well as the heating air, are automatically regulated in the new SP Dual compact with just one servomotor. This means that in every stage of the heating process - from heating up to burnout - the exact amount of air is supplied, creating the perfect combustion conditions. Furthermore, thanks to the regulated air supply for pre-heating, the door can be closed just a short time after lighting. Heating with firewood can be that easy!

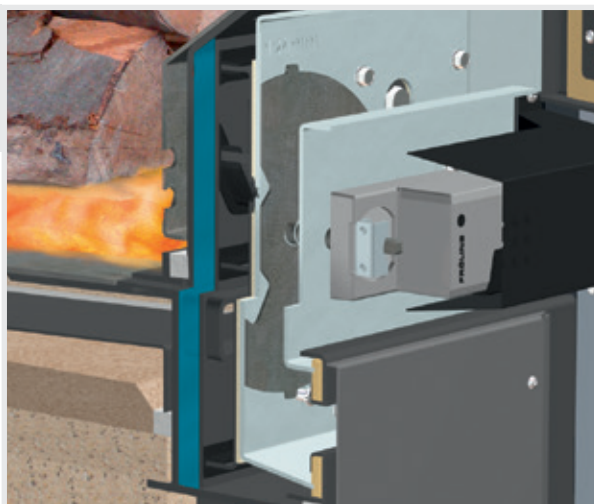

Feature: special carbonisation gas extraction system

- Advantages:
- Easy pre-heating
 - No flue gas escapes during reloading
 - Boiler room stays clean

The integrated carbonisation gas duct flap makes pre-heating even easier. The flap is closed manually before lighting to provide a better draught during the pre-heating process. The carbonisation gas duct flap opens automatically when the fuel loading chamber door is closed. This then reactivates the carbonisation gas extraction system, thus preventing smoke and gas from escaping when reloading.

SP Dual compact

**NEW! OPTIONAL WITH
AUTOM. WOS-TECHNIK**

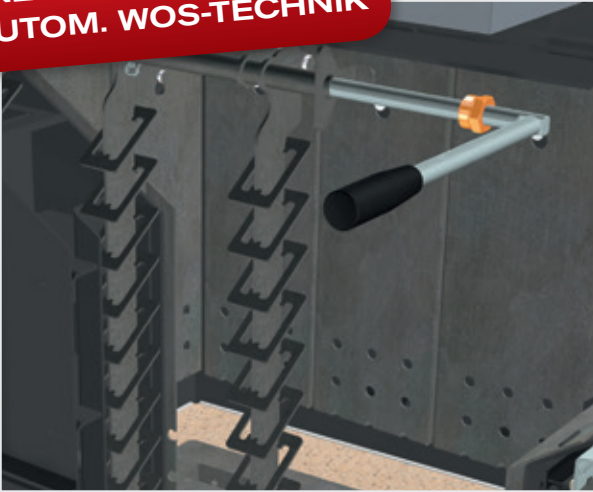

Feature: WOS system as standard

- Advantages:
- Even more efficient
 - Easy cleaning from outside
 - Fuel economy

We never compromise on convenience. The WOS (Efficiency Optimisation System), which comes as standard on the SP Dual compact, consists of special turbulators, which are placed in the heat exchanger pipes. The lever arm mechanism ensures easy cleaning of the heating surfaces from the outside. An additional benefit of this mechanism is that it ensures higher efficiency and fuel savings.

Feature: Automatic ignition

- Advantages:
- quiet operation
 - low energy consumption

The new glow ignition is particularly suitable for low boiler outputs. As it is operated without an additional blower fan, the glow ignition is barely audible.

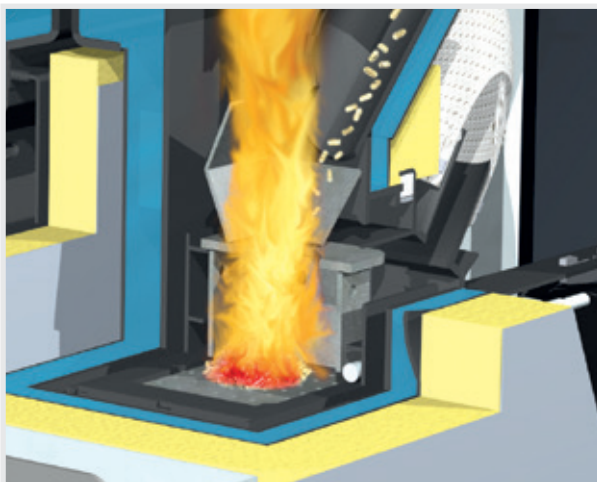
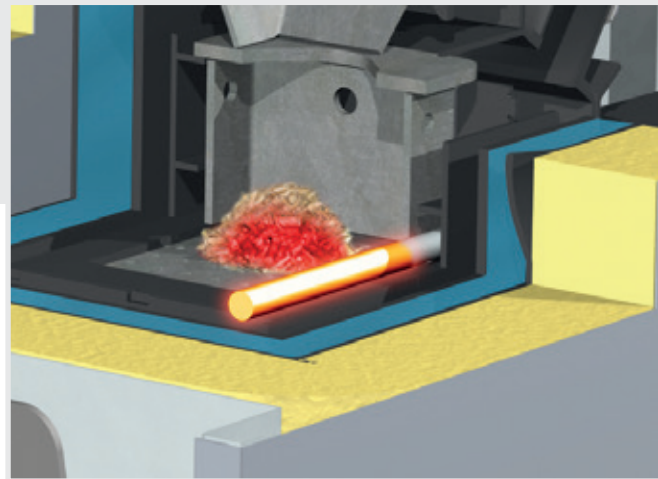

Feature: Water-cooled pellet burner with automatic sliding grate

- Advantages:
- high efficiency
 - Long lifespan
 - automatic ash removal

The water-cooled pellet burner is perfectly adapted to the fuel requirements enabling a particularly high level of efficiency. The sliding plate ensures automatic cleaning and ash removal into a large ashcan, thus ensuring convenient and maintenance-free operation.

Efficiencies
up to 102.8%

Innovative: Condensing technology for combined boilers



The Fröling SP Dual compact boiler series is unique worldwide thanks to its **innovative condensing technology** (optional). The hidden energy in flue gas which escapes unused through the chimney in conventional solutions is harnessed by an additional heat exchanger located at the rear of the boiler and fed to the heating system. The Fröling SP Dual compact boiler series thus achieves a **boiler efficiency of up to 102.8 percent (Hu)**. Already back in 1996, Fröling received the

Innovation Award at the energy saving fair Wels for a calorific value application in the biomass sector, and the company is thus considered a pioneer in this technology. The heat exchanger is made from high-quality stainless steel. It is cleaned via a water rinsing system. The module can be retrofitted optionally.



Advantages

- Lower fuel costs
- Filtration of the flue gas
- Reduced emissions
- Automatic cleaning
- The condensing module can also be retrofitted at any time

SP Dual compact

Overview of condensing heat exchanger:

- 1 Heat exchanger made of stainless steel
- 2 Automatic rinsing device
- 3 Drain with siphon for condensate drainage

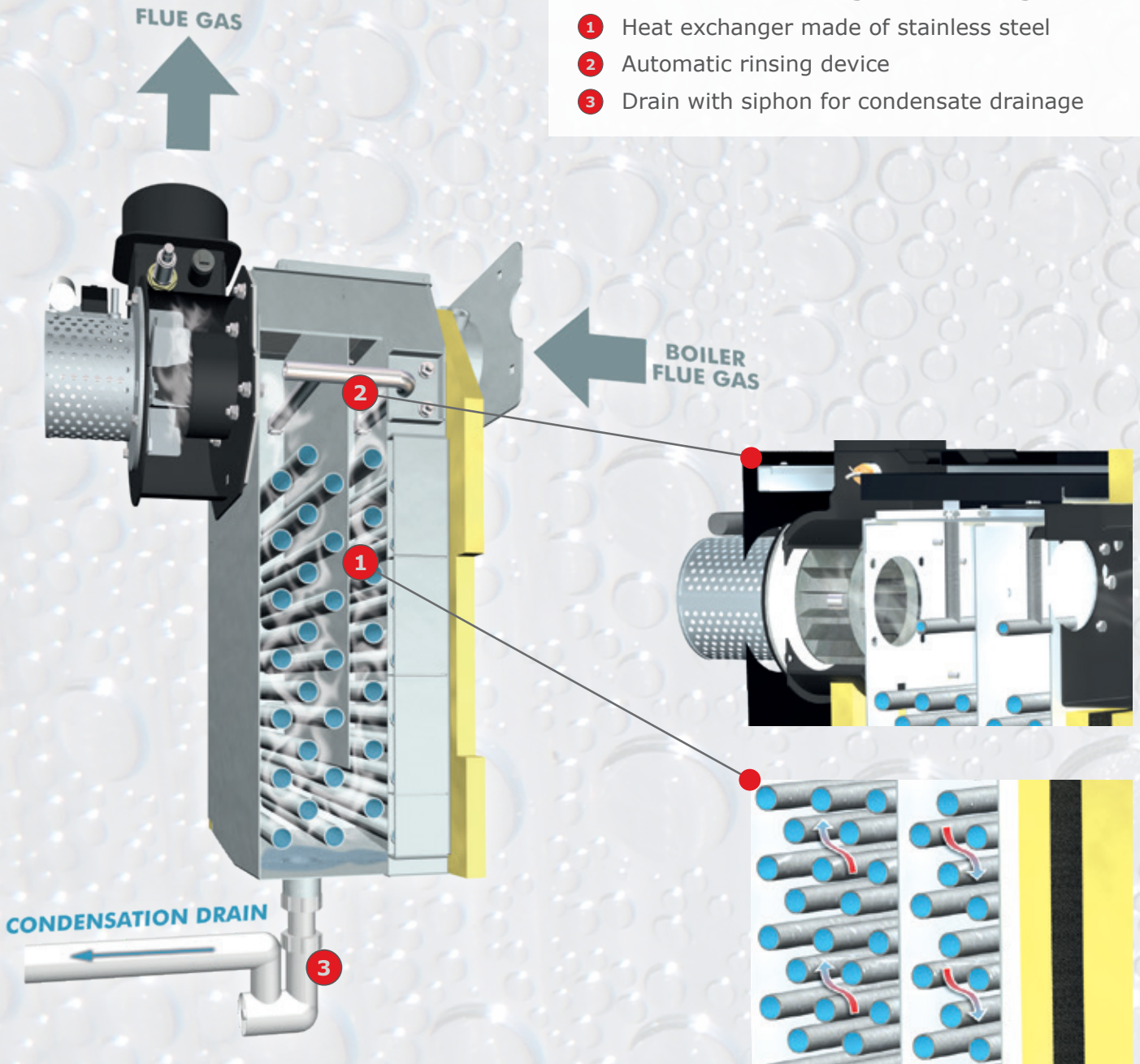

Requirements for optimal use of condensing technology:

- The return temperature should be as low as possible (e.g. floor or wall heating)
- Moisture-resistant and soot-fire-resistant exhaust system (W3G approval)
- Duct connection for condensate drainage and drainage of the rinse water

Feed systems

RS 4 / RS 8 pellet suction system

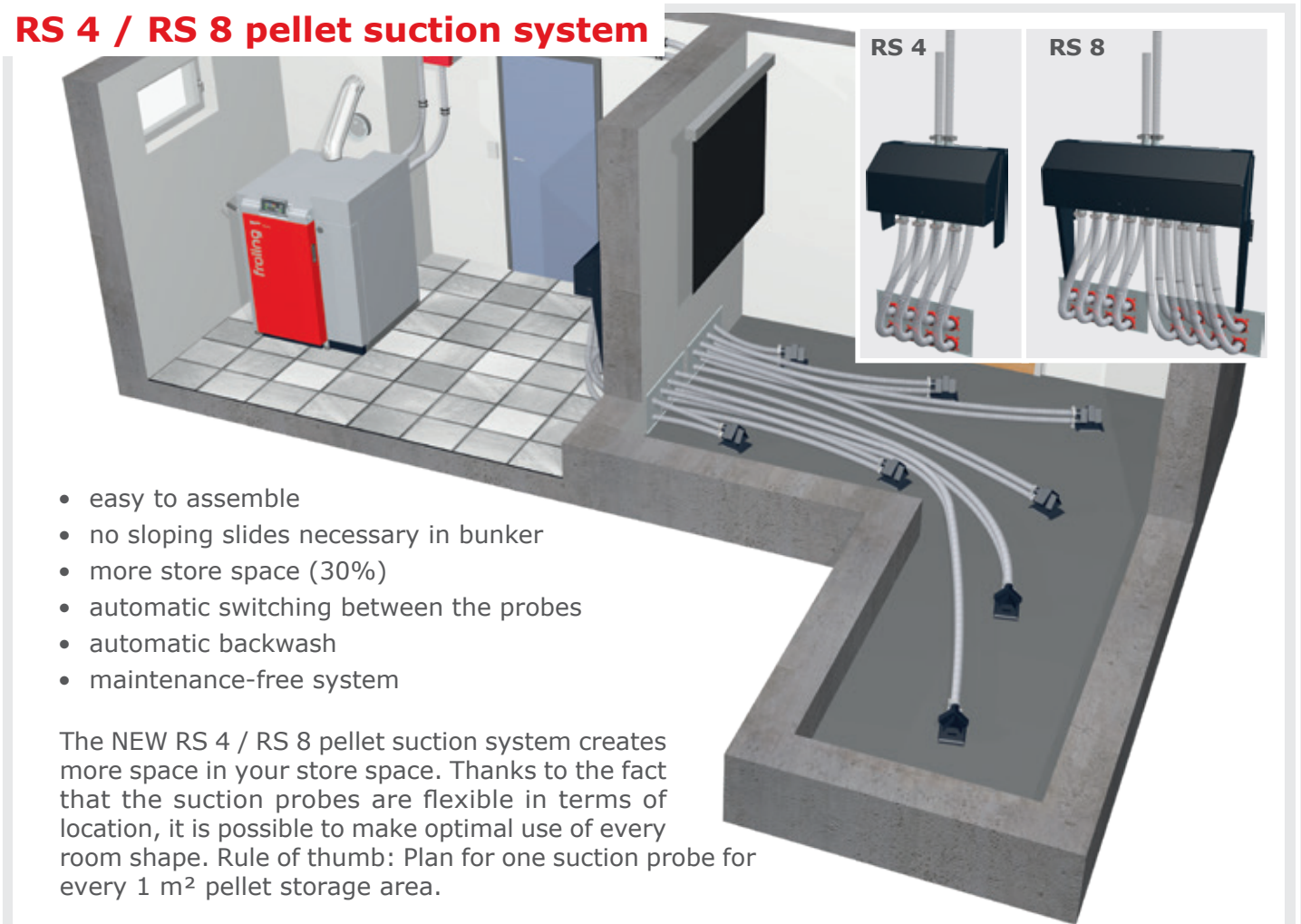

- easy to assemble
- no sloping slides necessary in bunker
- more store space (30%)
- automatic switching between the probes
- automatic backwash
- maintenance-free system

The NEW RS 4 / RS 8 pellet suction system creates more space in your store space. Thanks to the fact that the suction probes are flexible in terms of location, it is possible to make optimal use of every room shape. Rule of thumb: Plan for one suction probe for every 1 m² pellet storage area.

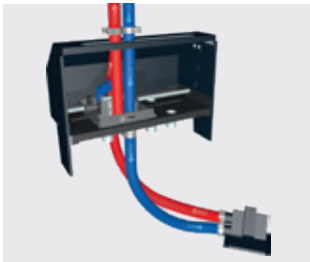

It automatically selects 4 or 8 suction probes in specified cycles, it is controlled by the pellet boiler. If, however, the suction probe fails unexpectedly, it is remedied by a **fully automatic reversal of the air supply (backwash)**.

Depiction: fully automatic reversal of flow

4 times suction system manual

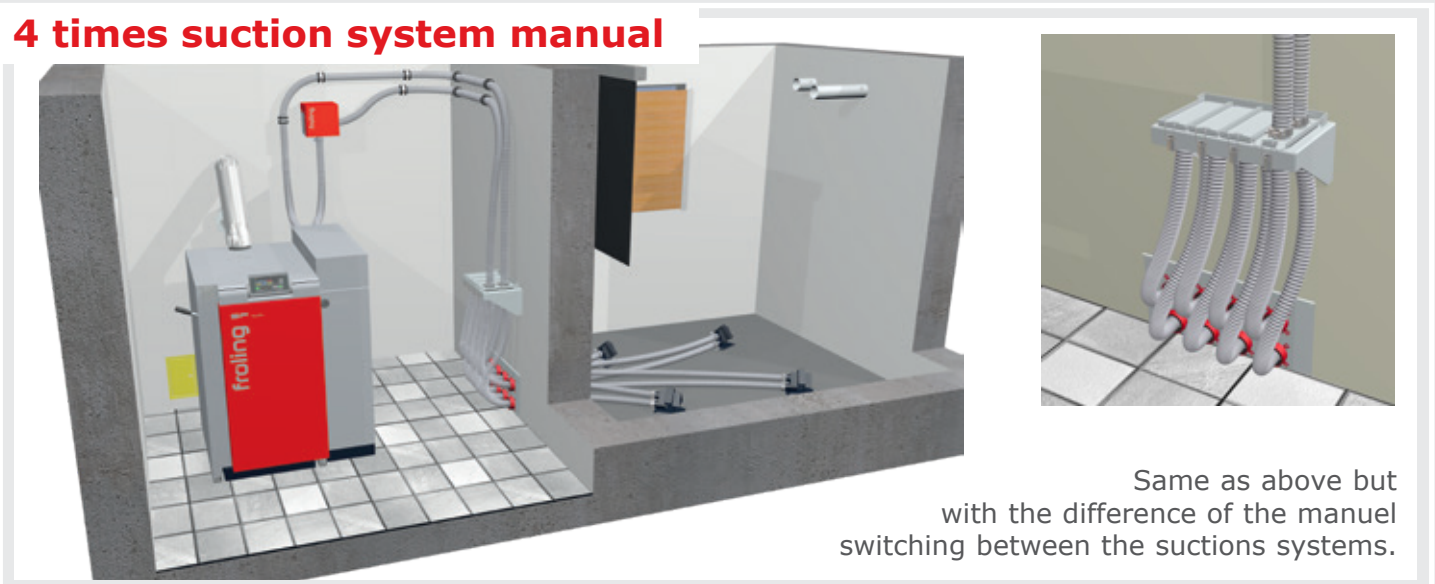

Same as above but with the difference of the manual switching between the suction systems.

SP Dual compact

Bag silo



The bag silo system is a flexible, simple way of storing pellets. Available in 9 different footprints (from 1.5 m x 1.25 m to 2.9 m x 2.9 m) with a capacity of between 1.6 and 7.4 tonnes, depending on the bulk density.

There are other advantages to using a bag silo. It is easy to assemble and dustproof. You can also fit rainproof and sunproof covers and install the silo outside.

Suction screw system

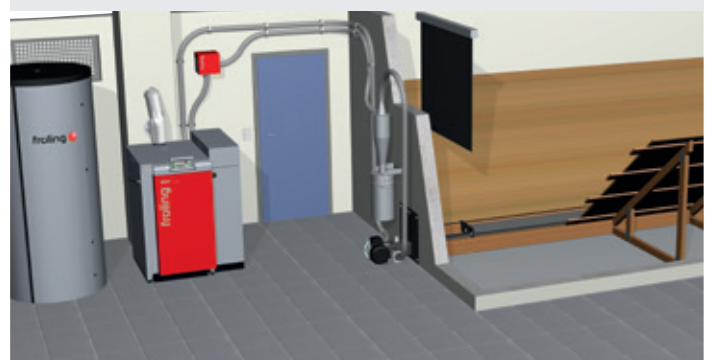

The Froling screw suction system is the ideal solution for rectangular rooms with front-end removal. The deep and horizontal position of the discharge screw means the space in the room is used optimally and complete emptying of the store is guaranteed.

Combined with a suction system from Froling it also enables flexible boiler installation.

For more information see our "Outfeeders for pellets" brochure



Cube 330/500S pellet supply bin

The Cube 330/500S is the optimal and most cost-effective solution for low fuel requirements. Manually filled (e.g. pellets in sacks) it can store a total of 330 kg/495 kg of pellets. The pellets are transported to the boiler by means of a suction probe, which is also included in delivery.



Pellet Mole®

This pellet discharge system is easy to install and makes full use of the store space. The Pellet Mole® draws the pellets from above, ensuring an optimum fuel feed to the boiler. The Pellet Mole moves automatically into every corner of the store to empty it as efficiently as possible.



External suction module

An external suction module is used for automatic fuel feed from the store to the pellet container. The suction module is fitted in the return line in any position.



Pellet filling pipes

The pellets are delivered by tanker and blown into the store through a filling pipe. The second pipe is used for controlled and dust free removal of the escaping air.

System convenience

Lambdatronic S 3200 control

With the new Lambdatronic S 3200 boiler controller, Froling is taking a step into the future. The control unit is optimised to suit any requirement. An individually adjustable viewing angle ensures that all operating statuses are clearly displayed. Exact combustion control thanks to lambda control **with broadband probe** as standard. The menu structure is ideally organised to ensure easy operation. All essential functions can be selected by simply pressing a button.



Lambdatronic S 3200 control

Advantages:

- Exact combustion control with broadband probe lambda control
- Large, clear control unit

NEW! 7" Touch-Display

Advantages:

- Individual installation of your own heating system
- Even more comfortable operation of the boiler thanks to a larger touch screen

NEW! SIMPLIFICATION OF BOILER SOFTWARE

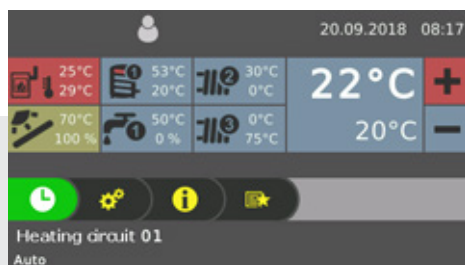

Fig. 1 General overview of heating circuit



Fig. 2 View of the chimney sweeper function

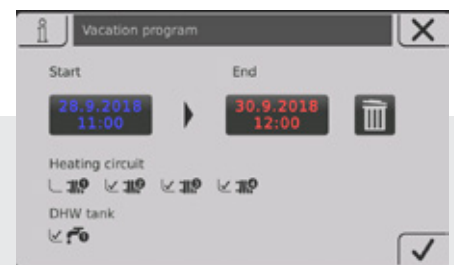

Fig. 3 Overview of the new holiday mode

Firewood reload calculation

Too much firewood can result in fuel that is not completely burnt despite the storage tank being loaded. The integrated reload calculation can be used through simple parameterization of the storage tank type and the storage tank volume. Taking into account the current storage tank charge, the boiler control calculates the missing energy. When the boiler door is opened, the required amount of fuel for loading the storage tank is displayed in kilogrammes.



NEW:

EVERYTHING AT A GLANCE WITH THE NEW FROLING APP

- ✓ Simple and intuitive operation of the boiler
- ✓ Status information can be called up and changed within seconds
- ✓ Individual naming of the heating circuits
- ✓ Status changes are transmitted directly to the user (e.g. via e-mail or push notifications)
- ✓ No additional hardware required (e.g. Internet gateway)



With the new Froling App, you can check and control your Froling boiler online from anywhere at any time. You can read and modify the main status information and settings easily and conveniently online. You can also specify which status messages you want to be informed about via SMS or e-mail (e.g. when the ash box is to be emptied or in the event of a fault message).

With optimized tablet view!

Froling boiler (software core module from version V50.04 B05.16) with boiler touch display (from version V60.01 B01.34), a (broadband) internet connection and a tablet/smartphone with IOS or Android operating system. Once the boiler has been connected to the internet and activated, the system can be accessed 24/7 from anywhere using a web-enabled device (mobile, tablet, PC, etc.). The app is available in the Android Play Store and IOS App Store.

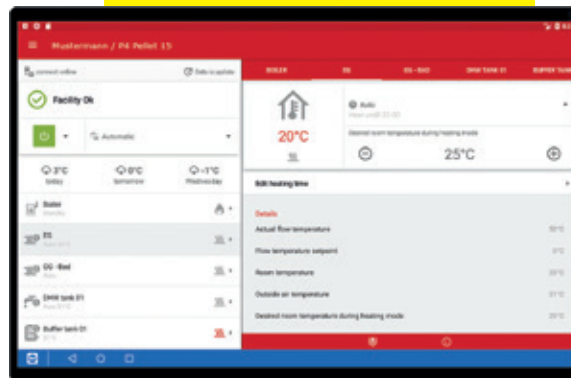

**SMART
HOME**

FLEXIBLE SOLUTION



Enjoy smart, convenient and piece-of-mind living with the Smart Home connection options from Froling.

Loxone: Combine your Froling heating system with the Loxone Miniserver and the new Froling Extension and implement individual boiler control on the basis of the single room control of the Loxone Smart Home.

Advantages: Easy operation and viewing of the heating circuit via the Loxone Miniserver, immediate notification of status changes and individual operating modes for each situation (presence, holiday, economy mode, etc.)

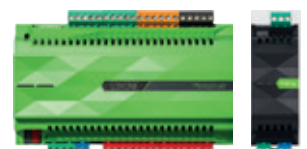

Mod bus: Via the Froling mod bus interface, the system can be integrated into a building management system.

System convenience

Accessories for even greater ease of use



FRA room temperature sensor

By using the Froling FRA room temperature sensor (measuring only 8x8 cm), the main modes of the corresponding heating circuit can be easily selected and adjusted. The FRA room temperature sensor can be connected with or without affecting the room area. The adjusting wheel allows you to change the room temperature by up to $\pm 3^{\circ}\text{C}$.



RBG 3200 Touch room console

The RBG 3200 Touch has an impressive touchpad interface. The menu structure means it is intuitive and easy to use. The 17x10 cm console with colour screen shows the most important functions at a glance and automatically adjusts the background lighting to the conditions. The room consoles are connected to the boiler controller using a bus cable.

SP Dual compact

Feature: systems engineering for optimum energy consumption

- Advantages:
- Complete solution for all requirements
 - Components work perfectly together
 - Integrated solar power

Froling systems engineering offers efficient energy management. Up to 4 storage tanks, 8 hot water tanks and 18 heating circuits can help manage the heating. You can also benefit from the ability to integrate other means of energy production such as solar panel systems.

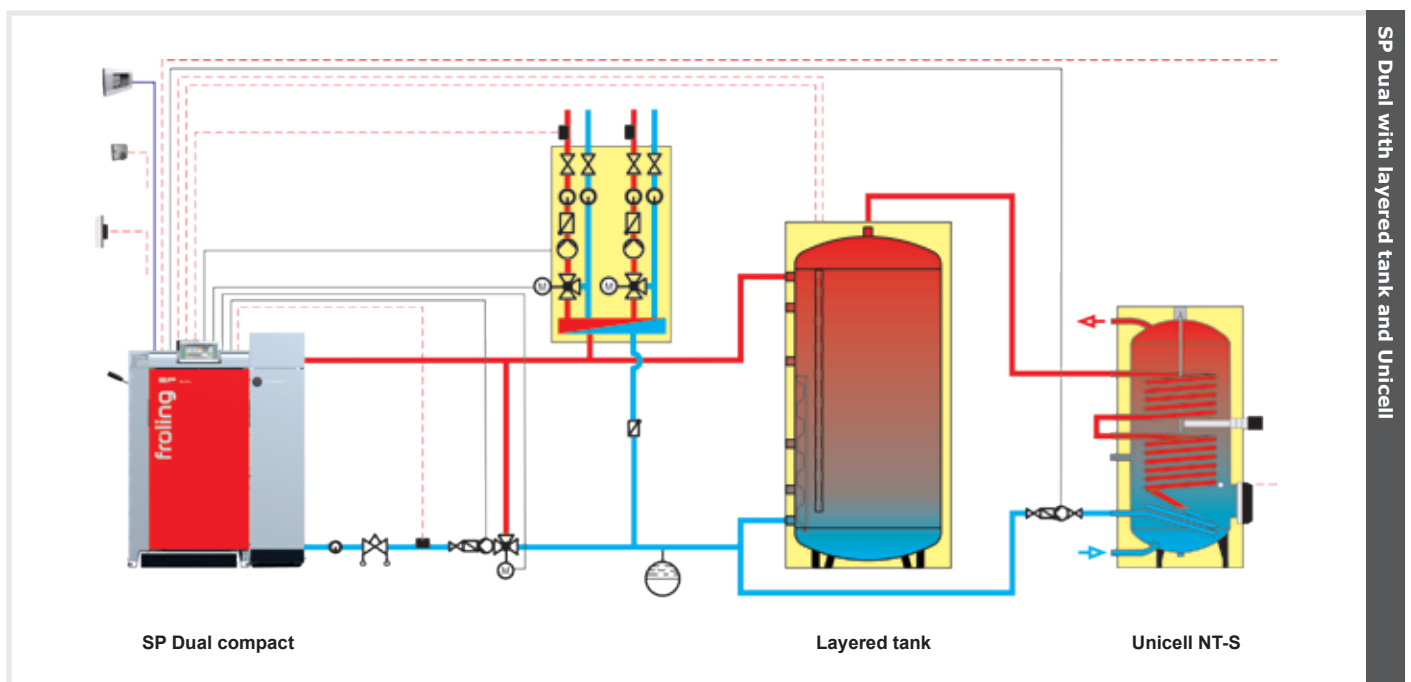

SP Dual with layered tank and Unicell

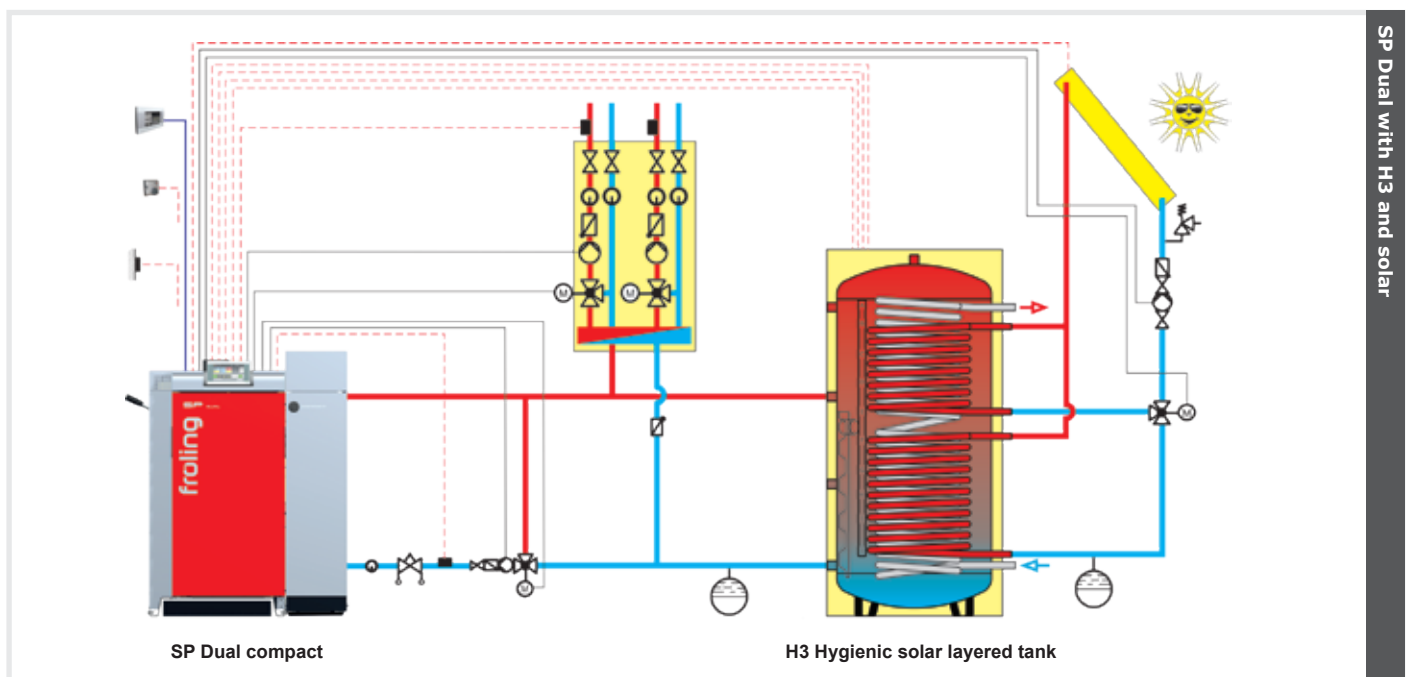

SP Dual with H3 and solar

Minimum distances in the boiler room

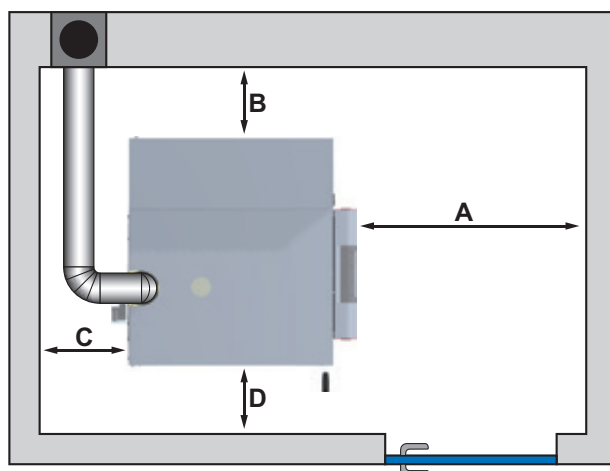

Minimum distances		SP Dual compact
A	Distance between insulated door and wall	[mm] 800
B	Distance between side of boiler with WOS lever and wall	[mm] 500
C	Distance between rear of boiler and wall	[mm] 400
D	Distance between side of boiler with WOS lever and wall	[mm] 200

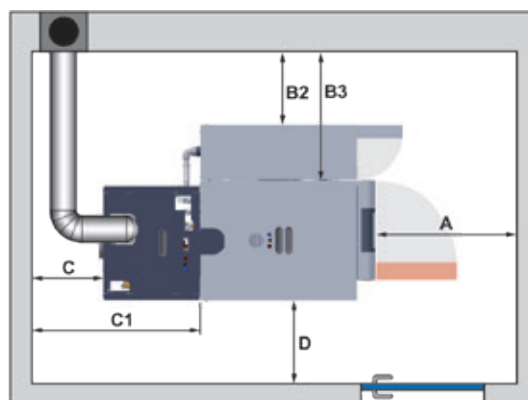
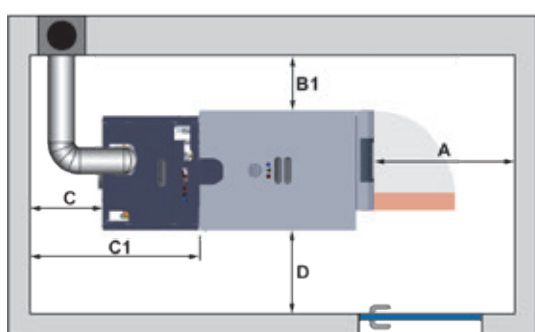

Minimum distances - SP Dual compact to condensing technology		
A	Distance from insulated door to wall	[mm] 800
B	Distance from boiler side to wall, S1 Turbo	[mm] 200
B2	Distance from boiler side to wall, SP Dual compact	[mm] 500
B3	Distance from boiler side to wall, S1 Turbo with retrofitted pellet unit	[mm] 815
C	Space requirements including maintenance area for draft fan with condensing heat exchanger	[mm] 250
C1	Space requirements for retrofitting a condensing heat exchanger	[mm] 800
B	Distance from boiler side to wall	[mm] 500 (200*)

* The boiler's heat exchanger can only be maintained/serviced from the front.

SP Dual compact

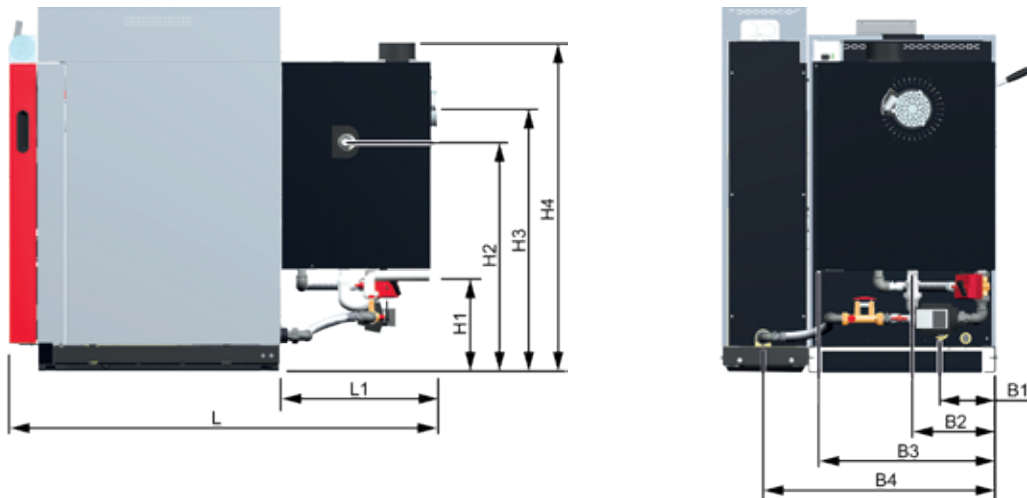

Dimensions - SP Dual compact with condensing technology

L	Length of boiler + condensing heat exchanger	[mm]	1575
L1	Length of condensing heat exchanger	[mm]	575
B1	Distance from boiler return to boiler side for S1 Turbo	[mm]	200
B2	Distance from condensate drain to boiler side	[mm]	305
B3	Width of condensing heat exchanger	[mm]	650
B4	Distance from boiler return to boiler side for SP Dual compact	[mm]	850
H1	Height of condensate drain connection	[mm]	245 - 350
H2	Height of return connection	[mm]	840
H3	Height of draft fan connection	[mm]	965
H4	Height of exhaust pipe connection	[mm]	1205
DI	Exhaust connection	[mm]	132
	Exhaust diameter	[mm]	130

Technical data - SP Dual compact with condensing technology

		15	20
Nominal heat output - Log wood operation / pellet operation	[kW]	16.5 kW / 4.8 - 16.5 kW	21.4 kW / 4.8 - 21.4 kW
Boiler efficiency	[%]	101.9	102.8
Energy label*			
Electrical power	[W]	58	55
Hopper capacity	[l]	80	
Filling door (width/height)	[mm]	350/360	
Water content - log boiler / pellet unit	[l]	90/15	
Weight of the condensing heat exchanger	[kg]	120	
Capacity of the pellet container (automatic charging)	[kg]	40	

* Configuration label (boiler + control + calorific value)

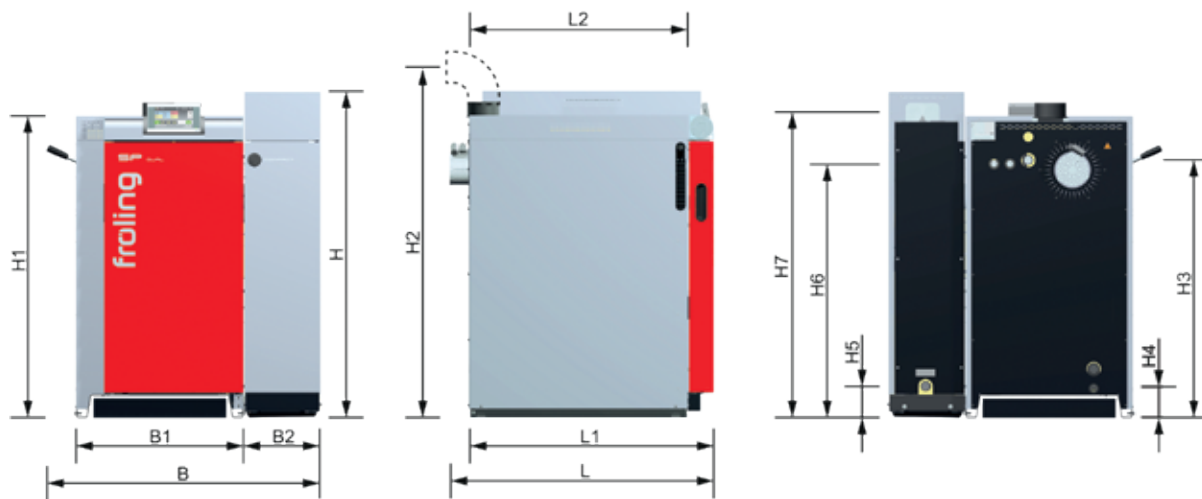

Dimensions - SP Dual compact		15	20	
L	Total length incl. induced draught fan	[mm]	1080	1080
L1	Length, firewood boiler	[mm]	1000	1000
L2	Length, pellet unit	[mm]	895	895
B	Total width, SP Dual compact incl. WOS lever	[mm]	1105	1105
B1	Width, firewood boiler	[mm]	685	685
W2	Width, pellet unit	[mm]	315	315
H	Overall height, SP Dual compact	[mm]	1335	1335
H1	Height, firewood boiler	[mm]	1235	1235
H2	Height of flue gas pipe connection	[mm]	1450	1450
H3	Height of flow connection	[mm]	1055	1055
H4	Height of drain connection	[mm]	125	125
H5	Height of return connection	[mm]	130	130
H6	Height of safety heat exchanger connection	[mm]	1040	1040
H7	Height of suction system connection	[mm]	1253	1253
	Flue gas pipe diameter	[mm]	130	130

Technical specifications - SP Dual compact		15	20	
Nominal heat output - firewood operation / pellets operation		[kW]	15/15	20/20
Output range - pellet operation		[kW]	4,4-15	4,4-20
Energy (ErP) label*			A ⁺	A ⁺
Weight - firewood boiler / pellet unit		[kg]	455/190	465/190
Water content - firewood boiler / pellet unit		[l]	90/15	90/15
Fuel loading door dimensions - firewood boiler (width/height)		[mm]	350/360	350/360
Fuel loading chamber capacity - firewood boiler		[l]	80	80
Pellet container capacity (automatic feed)		[l]	40	40

* Composite label (boiler + controls)

Your Froling partner:



**Heizkessel- und Behälterbau GesmbH
A-4710 Grieskirchen, Industriestr. 12**

AT: Tel +43 (0) 7248 606 • Fax +43 (0) 7248 606-600
DE: Tel +49 (0) 89 927 926-0 • Fax +49 (0) 89 927 926-219
E-mail: info@froeling.com • Internet: www.froeling.com